

BD65-1

CRAWLER DOZER



Salient Features :

- BEML -B6D125-1 Engine(Std.) & BEML TurboCharged BS6D125-1 (Optional)
- Power shift Transmission
- Wet Multiple disc steering clutches and brakes
- Arm chair steering controls
- Joystick control for work attachment
- Longer track
- Floating seals
- Dust seals
- Comfortable Operator seat
- Simple maintenance



BD65-1

Flywheel Power (FHP) : 1) Standard : 123kW (165HP)

2) Optional : 134kW (180HP)

Operating Mass : 18830 kg
(With Angle Dozer & Cabin)

www.bemlindia.in

BD65-1

CRAWLER
DOZER

Salient Features :

BEML Engine:

Diesel Engine : Direct-Injection system for high fuel efficiency and for cleaner exhaust, at high altitude.

Power Shift Transmission : For Smooth power shifting and make instant speed and directional changes by a single lever.

Wet steering clutches and brakes : For long service life. They are interconnected to perform quick steering actions.

Arm chair Steering Controls:

Controls for operator ergonomics

JoyStick Control for work attachment: It offers effortless control for all blade operations.

Longer Track:

For high machine balance cum stability and powerful traction even on soft terrains.

Floating Seals:

In idlers and rollers for preventing entry of dirt for durable life

Dust seals:

Between link, bushing and pin to prevent abrasive dirt or mud entry and ensure longer track life.

Comfortable Operator Seat :

Is adjustable in fore / aft for operator's convenience

Simple maintenance:

Spin-on type full flow fuel filters, air cleaner with automatic dust evacuator and dust indicator, external control valve and cable linkages

Cabin :

Spacious better visibility and operator safety with ergonomically positioned controls for better operator comfort.

Durable Structures:

All structural parts and systems are well proven for different working environments, maximum equipment availability and for more productivity.



ENGINE

Make	BEML
Model	Standard: B6D125-1 & Optional : BS6D125-1
Type	Standard: Diesel 4 stroke, water cooled, (turbo charged for BS6D125-1), direct injection
Fly wheel Power	Standard:123kW (165HP) Optional:134 kW(180 HP) @1850 rpm in accordance with IS:13116 / ISO:9249
Max. Torque	765 N-m (78 kg-m) at 1000 rpm
No. of Cylinders	6, inline
Bore x Stroke	Dia.125 x 150 mm
Displacement	11.04ℓ (0.01104 m ³)

ELECTRICALS

Alternator	24V,55A
Starting Motor	24V, 7.5kW
Battery	2 x 12V, 200Ah



POWER TRAIN

TORQUE CONVERTER

TYPE	3 Element, Single Stage, Single Phase
Stall ratio	2.9:1

TRANSMISSION

Model	planetary power shift 3F/3R
-------	-----------------------------



FINAL DRIVE

Type	Spur gear, double reduction
Lubrication	Splash Type
Total Reduction	16.66:1

TRAVEL SPEEDS m/sec (km/h)

Range	Forward	Reverse
1st	0-1.08 (0-3.90)	0-1.39 (0-5.0)
2nd	0-1.89 (0-6.80)	0-2.39 (0-8.60)
3rd	0-3.03 (0-10.9)	0-3.81 (0-13.7)



HYDRAULIC SYSTEM

Hydraulic Pump

Type	Gear pump
Capacity	245 lpm
Relief Pressure	13.73 MPa (140 kg/cm ²)

Hydraulic Cylinder

Type	Double acting piston type
Blade Lift	2 Cylinder
Bore x Stroke	Dia 110 mm x 1026 mm

Control Valve

Type	Pilot operated with joystick control
Position	Raise, hold, lower and float

STANDARD EQUIPMENT

- Power shift transmission
- Hydraulic track adjusters
- Dry horizontal type air cleaner with pre-cleaner
- Track roller guard(each side)
- Final drive case wear guard brakes
- Lighting system (2 Front,1Rear)
- Fixed type drawbar
- Segmented Sprockets
- Belly guard (2pieces)
- In-line radiator
- Adjustable operator's seat
- Tool kit and back-up alarm with flasher unit
- Angle Dozer attachment
- Hexagonal ROPS-FOPS Cabin

CONTROL PEDALS

- Brake (Left)
- Decelerator pedal
- Brake (Right)

SWITCHES

- Starting Switch
- Horn Switch
- Light Switch

CONTROL LEVERS

- Steering (Right)
- Steering (left)
- Gear-shift
- Safety lock for gear shift
- Blade control (Joystick)
- Fuel control
- Brake lock lever
- Safety lock for blade

METERS & GAUGES(LCD DISPLAY)

- Oil temperature gauge (torque convertor)
- Engine oil pressure gauge
- Engine water temperature gauge
- Engine oil pressure indicator
- Tacho hour meter
- Battery charging indicator (lamp)
- Dust indicator
- Preheater indicator
- Dip Stick for checking Fuel level

OPTIONAL ATTACHMENTS

- AC with Heater
- Defroster
- Multi Shark Ripper
- Coal Blade
- Straight Blade
- SU Blade
- AFDSS
- Rake Dozer
- Canvas Canopy

STEERING

Type	Wet, multiple disc
Min. Turning radius	2.9m
Steering Control	Hand operated steering clutches are hydraulically boosted for light touch and activation

UNDER CARRIAGE

Suspension	Oscillation type, Equalizer bar
Track Frame	Box section, high tensile strength steel construction.
Track Pitch	1880 mm
Track Rollers	7 no. each side
Carrier Rollers	2 no. each side
Track Shoes	39 no. each side
Grouser Height	65 mm
Shoe Type	Single grouser
Shoe width	510 mm
Ground Pressure	68.7kPa (0.70kg/cm ²)
Ground contact Area	2.688m ²

FILTRATION

Engine	Replaceable cartridge type filter for lubrication as well as for fuel line.
Transmission	Replaceable element type filter.
Steering & Brake	One Magnetic oil strainer and a filter with replaceable element for both steering and braking.
Hydraulic System	Magnetic plug and replaceable element type filter.

MASS (approximate)

Operating Mass (Standard equipment with Angle dozer)	18830 kg
Shipping Mass (Basic tractor with lubricants, Hydraulic system, cooling system and 10% of fuel tank capacity)	16330 kg

DOZER ATTACHMENT

Dozer type	Straight	Angle	Coal	Semi-U
Overall length with dozer	5350	5360	5600	5430
Blade Length x Height	3400 x1150	3970 x1050	4450 x1540	3400 x1370
Max. Lift above ground	1162	1250	1230	1344
Max. drop below ground	642	545	705	584
Max. tilt adjustment	890	400	-	830
Blade Capacity (cum)	4.5	3.24	10.1	5.0
Additional ground pressure kPa (kg/cm²)	10.8 (0.11)	10.8 (0.11)	14.7 (0.15)	10.8 (0.11)
MASS in kg				
Dozer Attachment	2343	2500	3490	2420
Hydraulic control unit	520	400	520	520

DIMENSIONS mm

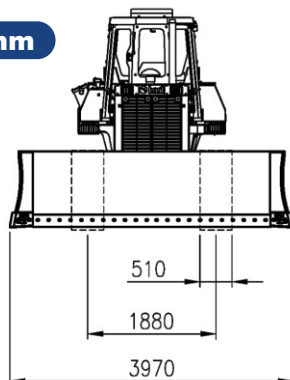

Ground Clearance : 400 mm

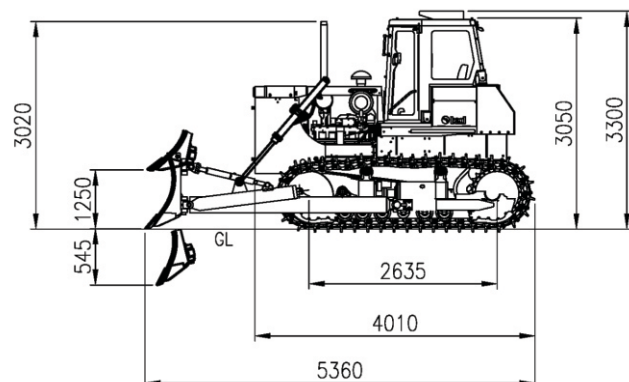

SYSTEM FLUID CAPACITY

System	Refill Capacity in ltrs.
Cooling System	45
Fuel Tank	320
Engine Oil Pan	26
Bevel Gear case and Steering	65
Torque Converter, Transmission	47
Final Drive (each side)	31
Hydraulic Oil	110

BRAKE

Type	Wet, Contracting Band
Actuation Type	Foot operated steering brakes with hydraulic booster for light touch actuation and long service life. Brakes and clutches are inter connected for easy steering.
Parking Brake	Hand operated with mechanical linkage

CABIN

Ergonomically designed Hexagonal shaped, ROPS-FOPS cabin provides excellent visibility and operator comfort.

INSTRUMENTATION

LCD based centralized monitoring system within the operator's cab has in-built diagnostics which allows fast daily checks and also keeps the operator constantly informed of any abnormality during operation. All important equipment parameters and warning indicators are displayed in the LCD display unit. The display unit is suitable for day and night visibility.

DRAW BAR PULL vs TRAVEL SPEED

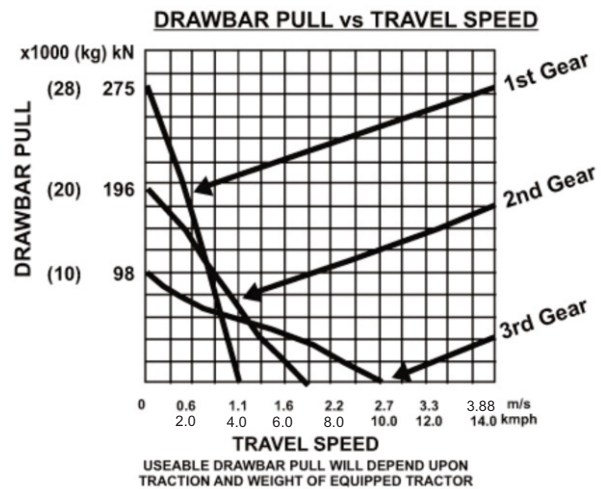

Material and specifications are subject to change without notice, illustrations may include optional equipment and accessories

बी ई एम एल लिमिटेड

BEML LIMITED

Schedule 'A' Company under Ministry of Defence, Govt. of India

Business Network

Corporate Office

BEML Soudha, 23/1, 4th Main,
S.R. Nagar, Bangalore – 560 027

T +91 80 22963240, 22963250

F +91 80 22963278/516/280/164

E-mail: office@cpd.beml.co.in
corpcomm@beml.co.in

International Business Division

Flat No. E,F,G, H, 'Vandana' 11th Floor,
11, Tolstoy Marg, Connaught Place
New Delhi – 110 001

T + 91 11 23316500
F + 91 11 23325085

E-mail: mx@beml.co.in

Marketing Division

5th Floor, Unity Building,
J.C. Road, Bangalore – 560 002

T + 91 80 22963501/02/07/510/540

F + 91 80 22963541

E-mail: m@beml.co.in
mmd@beml.co.in

REGIONAL OFFICES

Bangalore

3rd Floor, Unity Building, J. C. Road,
Bangalore - 560 002
Karnataka

T +91 80 2296 3524
T +91 97413 51588
E-mail: mg@beml.co.in

Bilaspur

1-A, Industrial Area, Sector-C, Sirgitti,
Bilaspur - 495 223.
Chhattisgarh

T + 91 7752 252745, 252598
F + 91 7752 252065
E-mail: mv@beml.co.in

Neyveli

F-4, Dr. Rajendraprasad Road,
Block-27, Neyveli, - 607 803
Tamil Nadu

T/F + 91 4142 268517
T + 91 4142 265517 / 229392
E-mail: ma@beml.co.in

Dhanbad

Mouza - Kangalo, Amaghata,
Govindpur, KG Ashram Post, Dhanbad
Jharkhand – 828 109

T + 91 94711 92023
E-mail: mf@beml.co.in

Hyderabad

3-6-114, Street No.18, Himayat Nagar,
Hyderabad - 500 029
Telangana

T + 91 40 2322 7032 / 94907 93117
F + 91 40 23221794
E-mail: hyderabad@rm.beml.co.in

Kolkata

35/1A, Taratala Road,
Kolkata - 700 088.
West Bengal

T + 91 33 2401 5286 / 87 / 98 / 99
F + 91 33 2401 5288
E-mail: kolkata@rm.beml.co.in

Mumbai

32A, Bazar Road,
Near Jain Mandir, Bandra (West), Mumbai,
Maharashtra - 400 050

T + 91 22 26431875 / 26435875
F + 91 22 26423928
E-mail: mumbai@rm.beml.co.in

Nagpur

No 33, Cement Road,
Shivaji Nagar,
Nagpur - 440 010, Maharashtra.

T + 91 712 2248435 / 2248343
F + 91 712 2249997
E-mail: nagpur@rm.beml.co.in

New Delhi

Flat E,F,G,H, 'Vandana', 11th Floor,
11, Tolstoy Marg, Connaught Place,
New Delhi - 110 001

T + 91 11 2344 3511 / 3528 / 2331 6500
F + 91 11 2332 5085
E-mail: mlm@rm.beml.co.in

Ranchi

206/D-1, Bhagirathi, (Behind NCC Campus)
Rameshwaram Colony, Bariatu Road,
Ranchi, Jharkhand - 834 009

T + 91 651 2540710 / 94311 08531
E-mail: ranchi@rm.beml.co.in

Sambalpur

BEML Complex, NH-6, Panchagachhia,
Baraipalli Post, Sambalpur 768 006
Odisha.

T + 91 663 2521604 / 2521389
E-mail: mb@beml.co.in

Singrauli

PB No. 5, Jhingurdha Colliery,
Singrauli - 486 889
Madhya Pradesh.

T + 91 7805 272668 / 272318
F + 91 7805 272282
E-mail: singrauli@rm.beml.co.in

ACTIVITY CENTRES

Bhopal

Ground Floor, Hall No.1, Chittod Complex, Zone-1,
Maharanapratap Nagar (MP Nagar), Bhopal - 462 011

T + 91 755 2550711 / 8989459753

Panjim

BEML Limited, 5/4, Victor Building, Fontanhas, Mala,
Panjim - 403 001, Goa

T +91 832 2225135 / 77986 87178
E-mail: goa@rm.beml.co.in

Itanagar

C/o. Tobom Riba, H-Sector, Papum
Itanagar – 791 113, Arunachal Pradesh

T + 91 94029 34205 / 88372 15852
E-mail: mcgi@beml.co.in

Kochi

No. 39/2122, Chittoor Road, Ernakulam South,
Kochi – 682 016

T + 91 484 2375138
E-mail: kochi@rm.beml.co.in

Maihar

Maihar, Madhya Pradesh

Mob: +91 79875 53768

Silapathar: Surya Vatika, Amritpur, Silapathar, Assam - 787 059 T +91 95311 29059

DISTRICT OFFICES

Ahmedabad

99/100, BEML HOUSE, 2nd Street,
Azad Society, Ambawadi,
Ahmedabad - 380 015, Gujarat

T + 91 79 26445523 / 94264 13620
F + 91 79 26423950
E-mail: ahmedabad@rm.beml.co.in

Asansol

3, Burnpur Road,
Asansol - 713 304
West Bengal

T + 91 341 2252480
F + 91 341 2250601
E-mail: asansol@rm.beml.co.in

Bacheli

Behind Central Stores of NMDC Ltd.,
Depot 5, Bacheli - 494 553.
Chhattisgarh

T/F + 91 7857 230005
E-mail: bacheli@rm.beml.co.in

Bhilai

Room no 22/C, BSP Expansion Building,
Near Ispat Bhavan, Bhilai 490 001, Chhattisgarh

T + 91 788 2223880
F + 91 788 2221652
E-mail: mnboffice@beml.co.in

Bhubaneswar

252/A, Lewis Road
Bhubaneswar - 751 014
Odisha

T + 91 674 2434427 / 99373 83950
E-mail: mbb@beml.co.in

Chandrapur

Mamidwar, Tiles Factory Compound
Ghugus Road, Padoli
Chandrapur - 442 406 Maharashtra

T + 91 7172 287230
F + 91 7172 287560
E-mail: mnc@beml.co.in

Chennai

Fiat No. 10, Supriya Estates,
No.3, Sterling Road, Nungambakkam,
Chennai - 600 034, Tamil Nadu,

T + 91 44 28220844
F + 91 44 28257319
E-mail: chennai@rm.beml.co.in

Guwahati

No.11, Ward 43, Hengrabari Road,
Ganesh Puri, Dispur,
Guwahati - 781 006 Assam

T + 91 361 2232966
F + 91 361 2232967
E-mail: guwahati@rm.beml.co.in

Hospet

No.1431, Manjunatha Complex,
Bhagat Singh Nagar, Opp. KSSIDC Indl. Estate,
Dam Road, Hospet - 583 203, Karnataka

T/F + 91 8394 230172
E-mail: hospet@rm.beml.co.in

Jammu

62C, Block D/C, Gandhi Nagar,
Jammu tawi - 180 004
Jammu and Kashmir

T + 91 191 2459 437
F + 91 191 2430 447
E-mail: mlj@beml.co.in

Kothagudem

Old Project Planning Department,
Near SCCL Corporate Office,
Kothagudem - 507 101, Telangana

T + 91 8744 245572
F + 91 8744 245530
E-mail: kothagudem@rm.beml.co.in

Leh

174-B, (Near Royal Enfield Showroom),
Housing Colony, Leh, Ladakh -194 101

T + 91 1982 258828 / 94198 71008
E-mail : ml@beml.co.in

Ramagundam

Near SCCL TTC, Jawahar Nagar,
Behind CISF Camp, Godavarikhani - 505 209.
Peddapalli Dist.,Telangana

T + 91 8728 248299 / 94408 58441
E-mail: mhr@beml.co.in

Udaipur

20-B, Uchhab Bhavan, Bedla Road,
Fatehpura, Udaipur - 313 001.
Rajasthan

T + 91 294 2452054
E-mail: mwu@beml.co.in

Visakhapatnam

No. 8-45-11, 4th Lane, Vidyanagar Chinna Waltair Colony
Visakhapatnam - 530 003, Andhra Pradesh

T/F +91 891 2754608 / 83320 54590
E-mail: vizag@rm.beml.co.in

www.bemlindia.in

Represented by:

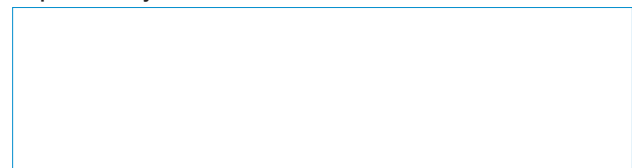

बी ई एम एल लिमिटेड

BEML LIMITED

Schedule 'A' Company under Ministry of Defence, Govt. of India

Crawler Dozers From BEML :

BD50

BD65-1

BD80

BD85

BD155

BD355

BD475

Form No. BD65-1/01/2020